

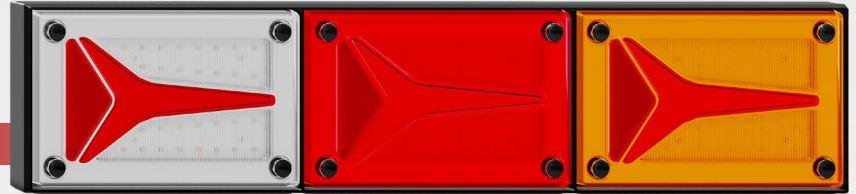

**LED Stop/Tail/Ind
& Reverse Lamp**
#595BARWM

www.ledautolamps.com



DESCRIPTION

12-24 Volt stop/tail/indicator & reverse lamp with reflector.

Features diffused tail function, IP67 rated water & dust protection and ECE Australian road approval. Equipped with rugged PMMA acrylic lens & ABS base. Pre-wired with 400mm cable.

5 year manufacturer warranty.



5 YEAR WARRANTY

FEATURES

- Stop/tail/indicator & reverse lamp with built-in reflector
- Multivolt input: 12-24 Volt
- ECE Australian Road Approved
- Powered by 111 high intensity LED's
- Surface mount
- Rugged PMMA acrylic lens & ABS base
- Pre-wired with a 400mm cable
- Waterproof up to IP67 rating
- Diffused tail function
- 5 year manufacturer warranty

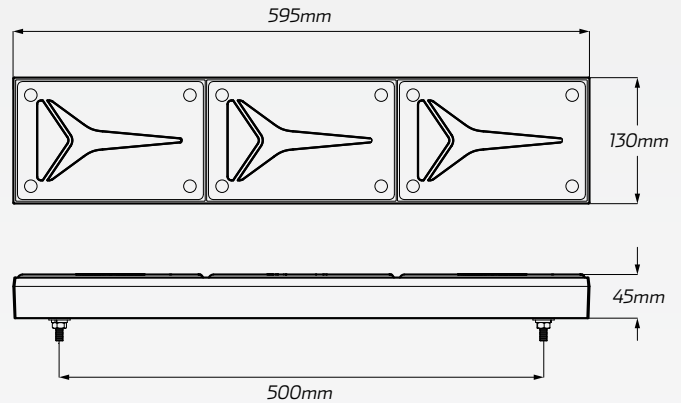

TECHNICAL SPECIFICATIONS

Voltage Range	• 12 - 24 Volt
Function	• Stop/tail/ind & reverse lamp with reflector
LED Count	• 111 LED's
IP Rating	• IP67 rated
Cable	• 400mm pre-wired cable
Current Draw	<ul style="list-style-type: none"> • Stop: 0.26A @ 13.8V / 0.12A @ 28V • Tail: 0.78A @ 13.8V / 0.40A @ 28V • Indicator: 0.25A @ 13.8V / 0.12A @ 28V • Reverse: 0.34A @ 13.8V / 0.16A @ 28V

Lens Material	• PMMA Acrylic lens
Base Material	• ABS base
Dimensions	• 595mm L x 130mm H X 45mm D
Mounting Type	• Surface Mount
Mounting Dimensions	• 500mm CTC
Approvals	<ul style="list-style-type: none"> • Stop/tail: ECE E9*7R02/27*23695*00 • Indicator: ECE E9*6R01/29*23693*00 • Reverse: ECE E9*23R00/22*23694*00 • Reflector: ECE E9*3R02/17*22372*00