



Heavy Duty Single Battery Fuse Holder

Sold Individually

www.eaton.com

DESCRIPTION

Heavy duty fuse holder to suit battery fuses.

Weatherproof, perfect for tight spaces and harsh environments. 6mm stud. Simple to set up and compact, mounts on a 3/8" battery post, battery switch or a buss bar.

Comes with a red cover or black cover. 300 Amps @ 12 Volt.

- Santoprene insulated cap
- ABYC 7 approved
- Weatherproof, suitable for Australia's harsh conditions



TECHNICAL SPECIFICATIONS

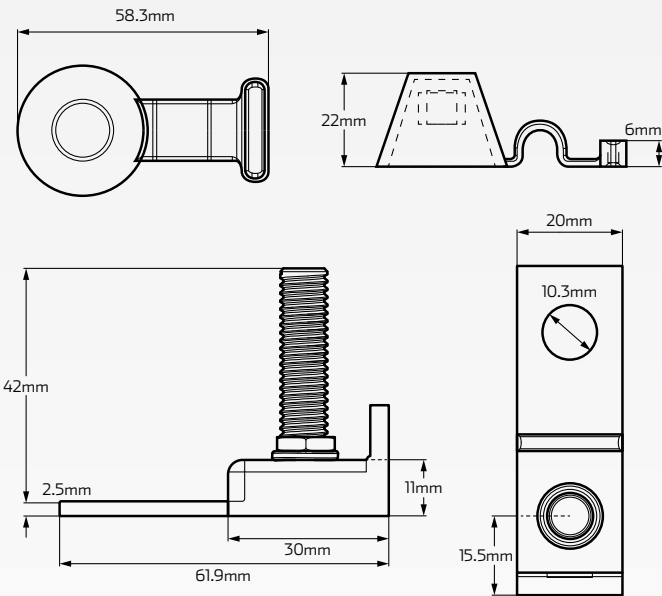

Voltage	• 58 Volt DC
Current Rating	• 300 Amps max per kit @ 12 Volt
Body Material	• Thermoplastic PPS UL94-V0
Bussbar Material	• Nickel plated copper
Bar Stud Size	• 1/4" - 20
Stud Material	• Stainless Steel
Applications	• DC Main, inverter, windlass & bow thruster circuit protection
Weatherproof	• Yes, with cover applied
Approval	• ABYC 7
Kit Contents	• S/S nuts, washers & cover

TECHNICAL SPECIFICATIONS

Part Number.	Cover Colour	Description
QVCFBARISP-KIT	• Red Cover	• Heavy duty fuse holder to suit battery fuses. Comes supplied with red cover. 300A @ 12V.
QVCFBARISP-KITB	• Black cover	• Heavy duty fuse holder to suit battery fuses. Comes supplied with black cover. 300A @ 12V.