

**QVEE**  
AUTOMOTIVE | MINING | MARINE

Midi Fuse Block  
With 50 Amp Fuse  
#QVMIDFB50BL

www.qvee.com.au

**DESCRIPTION**

Heavy duty midi fuse holder with 50 Amp fuse.  
Suitable for inline or surface mount applications.  
Includes cover and hex nuts.



**TECHNICAL SPECIFICATIONS (QVMID50)**

Fuse I.R	• 1000 Amps
Fuse Voltage	• 58 Volt DC
Fuse Amperage	• 60 Amp fuse
Fuse Mounting	• M5 Studs
Fuse Approvals	• ISO 8820-5, RoHS

% Amperage Rating	Opening Time	
	Min. Time	Max. Time
100%	100 hours	-
110%	4 hours	-
150%	90 seconds	1 hour
200%	3 seconds	100 seconds
300%	0.3 seconds	3 seconds
500%	0.1 seconds	1 second

**TECHNICAL SPECIFICATIONS (QVMIDFBB)**

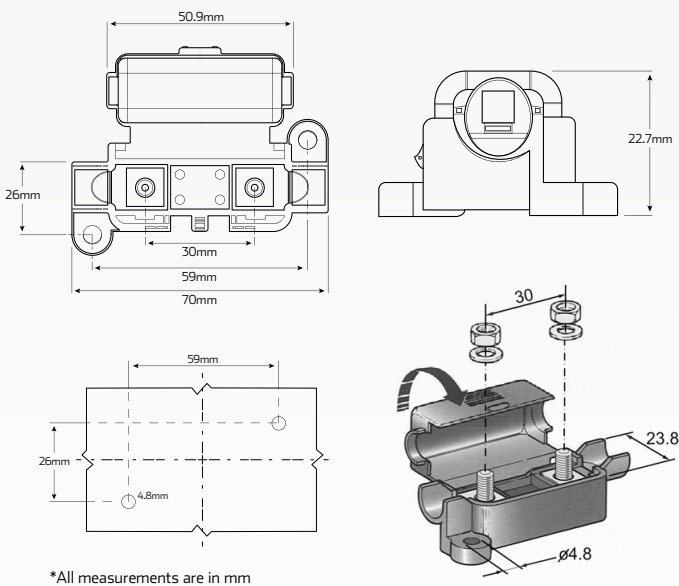

Withstanding Voltage	• Up to 58 Volt DC
Max. Amperage	• 125 Amps
Fuse Holder Material	• Black PA66, steel / zinc plated studs
Accessories	• Includes cover & hex nuts
Stud Size	• M5 threaded studs.
Dimensions	• 70mm L x 22.7mm H (when closed)
Fuse Holder Mounting	• 59mm x 26mm CTC, Ø 4.8mm hole
Fuse Holder Approvals	• RoHS