

**QVEE** Twin Midi Fuse Holder  
AUTOMOTIVE | MINING | MARINE #QVMIDFHD

www.qvee.com.au

**DESCRIPTION**

Heavy duty twin midi fuse holder.

Supports electrical applications of up to 150 Amps.  
Suitable for in-line or surface mount applications.  
Includes cover and hex nuts.



**DIMENSIONS**

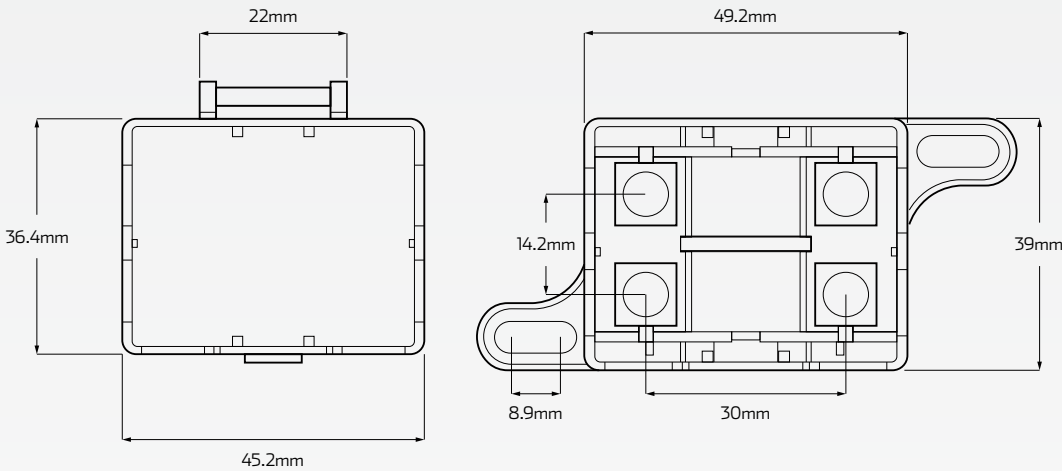

Suits Midi fuses up to 150A (total)

Fuses are not included

**TECHNICAL SPECIFICATIONS**

<b>Suitable Fuse</b>	• Midi fuses (not included)
<b>Max. Voltage Application</b>	• Up to 32 Volt applications
<b>Max. Current Application</b>	• Up to 150A max @ 12 Volt (total)
<b>Housing Material</b>	• Black PA66 nylon
<b>Accessories</b>	• Includes cover and hex nuts

<b>Stud Size</b>	• M5 threaded studs
<b>Flammability Protection</b>	• Yes
<b>Max. Flammability Temp</b>	• Up to 200°C
<b>Approvals</b>	• UL-94 V0 flammability rated