

**QVEE** Heavy Duty LED Rotating Beacon  
AUTOMOTIVE | MINING | MARINE #QVRB162

www.qvee.com.au

**DESCRIPTION**

The QVRB162 is a 100mm x 165mm Diameter Heavy Duty CLASS 1 rated LED Rotating Amber Beacon with polycarbonate lens.

Rugged design to suit all heavy duty applications including Mining, Transport, Shire, Traffic management etc.



**TECHNICAL SPECIFICATIONS**

<b>LED Count</b>	• 12 High Powered LED's	<b>Mounting</b>	• 3 Bolt Mount
<b>Wattage</b>	• 36 W	<b>Colour</b>	• Amber
<b>Voltage</b>	• 10 - 30 V DC	<b>Lumens</b>	• 1500 Lumens
<b>IP Rating</b>	• IP67 Rated	<b>Dimensions</b>	• 100mm H x 165mm D
<b>Lens Construction</b>	• Polycarbonate	<b>Flash Patterns</b>	• 6 different flash patterns including 4 unique alternate or simulated rotating flash patterns
<b>Base</b>	• Die - Cast		

**FLASH PATTERN**

1.	• Rotate - 120 fpm
2.	• Rotate - 85 fpm
3.	• Single Flash
4.	• Double Flash
5.	• Quad Flash
6.	• 2 - 3 - 4 - 5 Combined

**DIMENSIONS**

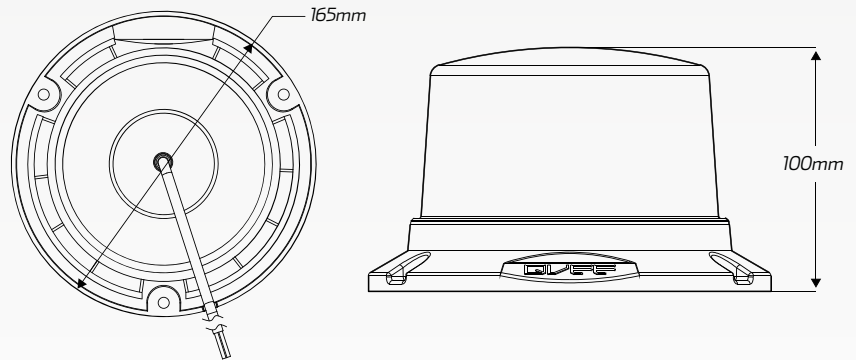

**WIRING DESIGNATION**

