

QVEE
AUTOMOTIVE | MINING | MARINE

Mine Bar with LED Beacon & Worklight

#RHBAR1250-B1B

www.qvee.com.au



PRODUCT BREAKDOWN

Part No.	Description	Qty
QVRB1	• Black alloy mine bar	• 1
QVCNKIT	• Channel nut kit, 8mm hole	• 5
QVRB162	• "QVEE" Heavy duty LED amber beacon	• 1
QV9L28WF	• "QVEE" 27W flood worklights	• 2
201BSTIB	• "LED Autolamps" stop/tail/indicators	• 2
QVRABWS	• "QVEE" 97dB dual tone reverse alarm	• 1
QVBRK5	• Black, powder coated flag/worklight bracket	• 3

DIMENSIONS

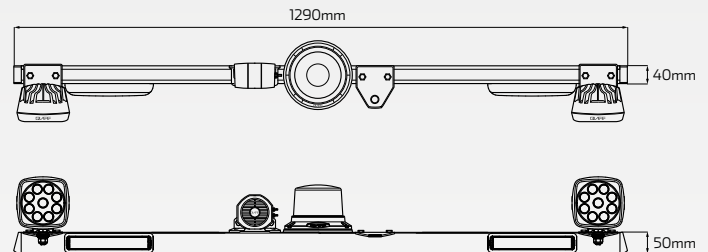

- Accessories come pre-assembled
- Beacon is mounted with BRK1, round beacon bracket
- Comes pre-wired with 2 pin male Deutsch connector & 7 core trailer cable

TECHNICAL SPECIFICATIONS

GENERAL SPECIFICATIONS

Bar Dimensions	• 1290mm L x 50mm H x 40mm D
Cable Wiring	• 3mm 7 core trailer cable (5m)

BEACON - QVRB162

LED Count	• 12 high powered LED's - 1,500 Lumens
Input Voltage	• 10 - 30 Volt DC, 36 Watt
Colour	• Amber, 6 different flash patterns
IP Rating	• IP67 Rated

REVERSE ALARM - QVRABWS

Sound Type	• "Beep Beep" & "Shhh Shhh" (change via switch)
IP Rating	• IP66 Rated
Decibel Level	• 97dB

FLAG / WORKLIGHT BRACKET - QVBRK5

Mounting Hole	• 14mm Diameter
Coating	• Black Powder Coating

STOP / TAIL / INDICATOR - 201BSTIB

Input Voltage	• 12 Volt only
IP Rating	• IP67 Rated
Approvals	• Stop - ADR Category 49/00 CRN 46885 • Tail - ADR Category 49/00 CRN 46885 • Indicator - ADR Category 49/00 CRN 46884

WORKLIGHT - QV9L28WF

Beam Type	• Flood beam
Lumens	• 9 High powered CREE® LED's - 2,700 Lumens
IP Rating	• IP68 Rated

MINE BAR WITH LED BEACON & WORKLIGHT

RHBAR1250-B1B Dimension Diagram

Dimensions:

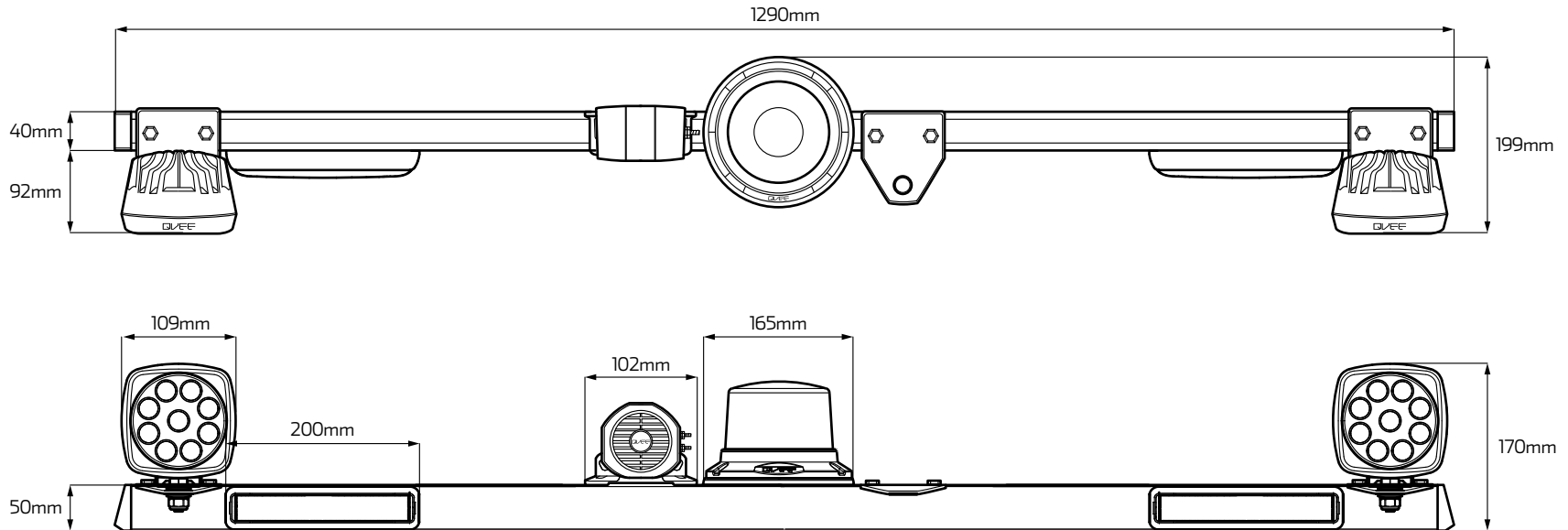

+Allowance of +/- 3mm.

*To avoid warranty issues QVEE recommends product are fitted by a qualified Auto Electrician.

1250MM / 1375MM / 1500MM MINE BAR Wiring Diagram

Wiring Diagram*:

